

Additional Topics Drill 1

This section contains two types of questions. For multiple-choice questions, solve each problem and circle the letter of the answer that you think is the best of the choices given. For Student-Response questions, denoted by the grid-in icon, write your answer in the blank space provided.

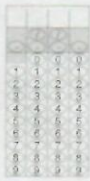
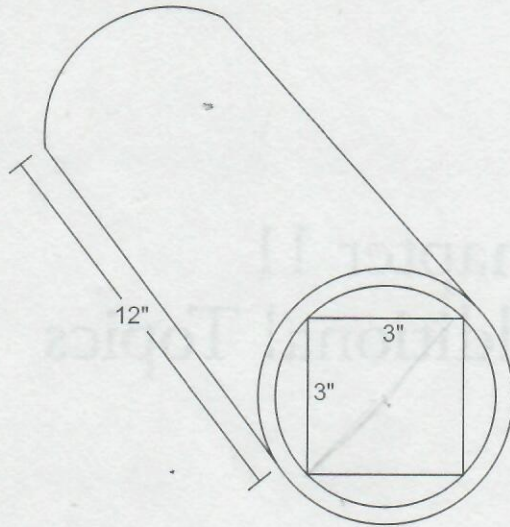

1. Roy has a block of wood in the shape of a rectangular solid with a width and height of 3 inches and a length of 12 inches. For the purpose of shipping, he places the block of wood in a cylindrical cardboard tube with an inside length of 12 inches, such that the four long edges of the block of wood touch the inside of the tube, as shown in the figure above. What is the inside volume, in cubic inches, of the tube before the block of wood is inserted? (Round your answer to the nearest cubic inch.)

2. A cylindrical water tank has a diameter of 20 meters and a height of 20 meters. If the tank currently holds 1600 cubic meters of water, what is the approximate depth of the water in the tank?
- A) 5 m
B) 10 m
C) 15 m
D) 20 m

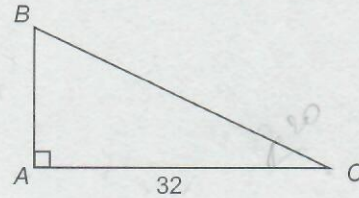

3. The figure above shows $\triangle ABC$. If $\angle ACB = 20^\circ$, which of the following is closest to the length of \overline{BC} ?
- A) 30
B) 31
C) 33
D) 34

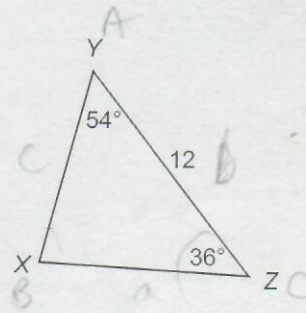

Note: Figure not drawn to scale.

4. In $\triangle XYZ$ shown above, $\angle XYZ = 54^\circ$, $\angle YZX = 36^\circ$, and $\overline{YZ} = 12$. What is the length of \overline{XY} ?
- A) 7.05
B) 8.71
C) 9.72
D) 13.93

Additional Topics Drill 2



5. If $i^2 = -1$ and $(4 + 2i)(6 - ki) = 30$, what is the value of k ?

- A) 3
- B) 4
- C) 6
- D) 8



6. What is the value of $(3 + 4i)(3 - 4i)$?

- A) 1
- B) 5
- C) 9
- D) 25

Additional Topics Drill 2

For each question in this section, solve the problem and circle the letter of the answer that you think is the best of the choices given.

1. If $0 < x < \frac{\pi}{2}$ and $\sin x = y$, what is the value of $\cos\left(\frac{\pi}{2} - x\right)$ in terms of y ?

- A) $-y$
- B) y
- C) y^2
- D) $1 - y^2$



2. Minor arc PQ in circle O below is 2π . If $\angle PQO$ is 45° , what is the area of the shaded region?

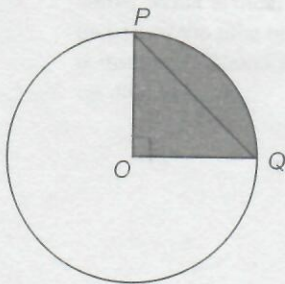

- A) 2π
- B) 4π
- C) 8π
- D) 16π



3. Points A and B lie on circle O as shown below. $\angle BOA$ is 45° . If the area of circle O is 64π , what is the length of minor arc AB ?

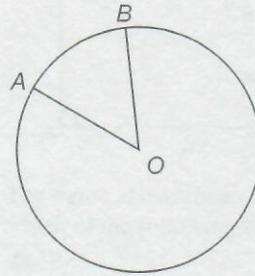

- A) 2π
- B) 4π
- C) 8π
- D) 16π

4. In the figure below, \overline{QS} and \overline{PT} are parallel. If $\overline{RS} = 8$, $\overline{PR} = 16$, and $\overline{PT} = 10$, what is the length of \overline{QS} ?

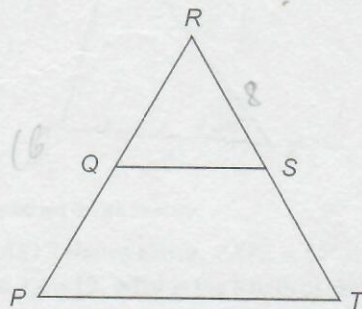

- A) 5
- B) 8
- C) 10
- D) 16

5. Right triangle ABC , shown below, has a base of 4 inches and a hypotenuse of 8 inches. If the height of the triangle is between 4 in and 8 in, what is the angle measure of $\angle C$?

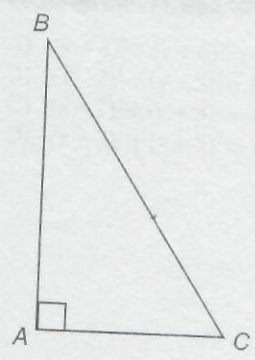

- A) 30
- B) 45
- C) 60
- D) 90

6. Lines l and m , shown below, are parallel. Lines a and b intersect as shown. If segment DE is 12 and CE is 6, which is the length of AB if AC is 18?

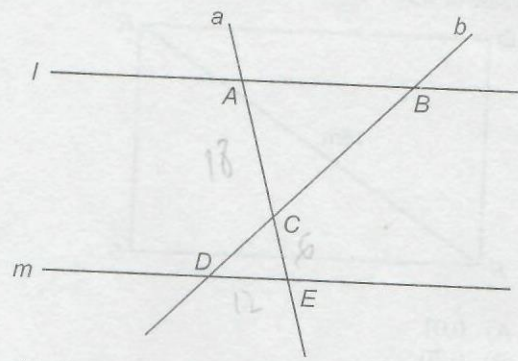

- A) 9
- B) 18
- C) 24
- D) 36

Additional Topics Drill 3

For each question in this section, solve the problem and circle the letter of the answer that you think is the best of the choices given.

1. In rectangle $PQRS$, shown below, the diagonal PR is 15 meters. If the sine of $\angle SPR$ is $7/10$, what is the value of RS ?

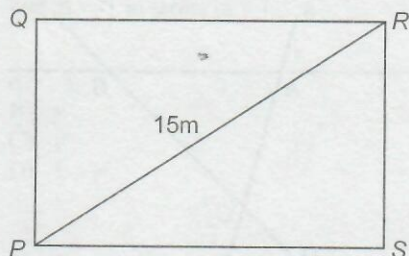

- A) 0.01
- B) 0.70
- C) 7.0
- D) 10.5

2. In the figure below, ABC is an isosceles triangle. The height of the triangle, BD , is 8 cm. $AB = BC = 10$. What is the value of $\tan C$?

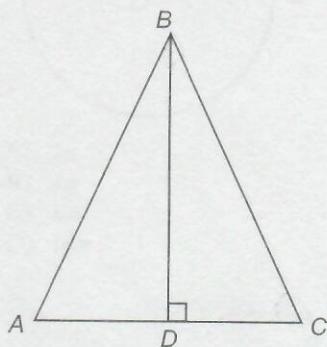

- A) $10/6$
- B) $6/8$
- C) $8/6$
- D) $6/10$

3. A child sits in a tree 9 meters off the ground. His line of sight to the ground forms a 36° angle with the tree. If he is looking at a cat on the ground, approximately how far is the cat from the base of the tree in feet?

- A) 6.5
- B) 11.0
- C) 13.8
- D) 15.0



4. In the xy -plane, a circle is centered on the origin and the point (p, q) lies on the circumference of the circle. What is the radius of the circle, in terms of p and q ?

- A) $p + q$
- B) $p - q$
- C) $p^2 + q^2$
- D) $\sqrt{p^2 + q^2}$

5. The diameter of the circle falls on the line $y = \frac{1}{2}x + 4$. If the radius of the circle is 4, which of the following could be the equation of the circle?

- A) $(x + 4)^2 + (y + 6)^2 = 4$
- B) $(x - 2)^2 + (y - 5)^2 = 16$
- C) $(x - 2)^2 + (y + 3)^2 = 4$
- D) $(x + 2)^2 + (y + 5)^2 = 16$

-
6. What is the radius of a circle represented by the equation $x^2 + y^2 - 6x + 4y = 12$?

- A) 5
- B) 4
- C) 3
- D) 2

Chapter 12
Additional Topics
Answers and
Explanations